

**\*CONFIDENTIAL\***

COMMERCIAL PILOT DIMENSIONS AND SPECS

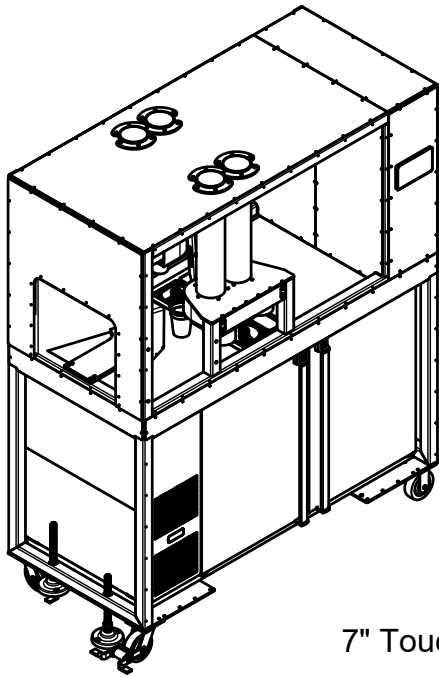

KEG CAPACITY:

- (2)  $\frac{1}{2}$  Kegs with (1)  $\frac{1}{4}$  Slim Kegs
- (6)  $\frac{1}{4}$  Slim Keg
- (8)  $\frac{1}{6}$  Kegs

CUP CAPACITY:

- (160) 20-oz
- More sizes upon request
- Refill w/o Stopping Robot

SERVING CAPACITY:

Low as 20 sec/drink

ELECTRICAL REQ:

115 VAC, 60 Hz, 1-ph, 15 A

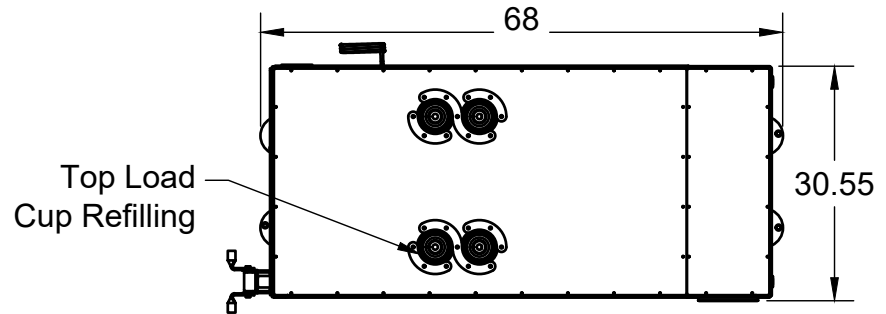

7" Touch Screen (Ordering and Tap Management)

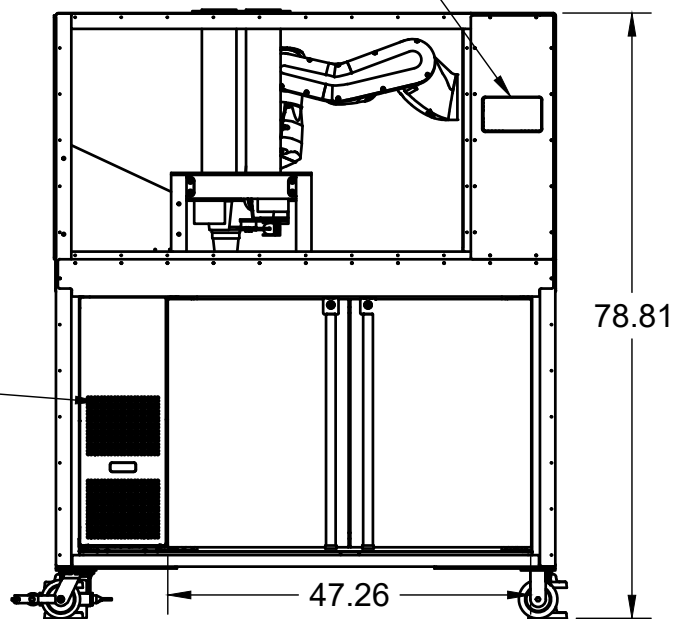
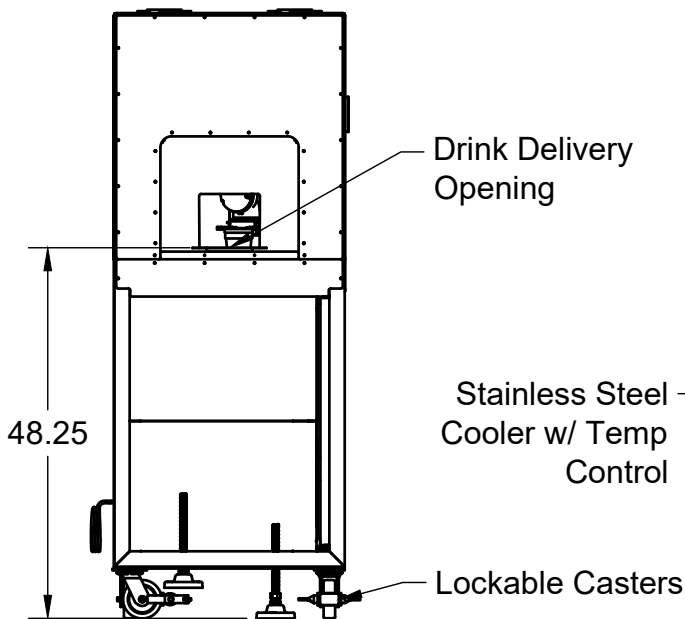

\*Cooler can be reversed if needed\*

Allow opening for door swing. Do not block compressor air flow

PATENT PENDING

PROJECT

**Hop Robotics, LLC**

TITLE

**COMMERCIAL PILOT SYS DWG  
4 Dispenser Unit**

Questions/Comments to: Grayson, dawson2667@gmail.com

APPROVED

CHECKED

DRAWN

Grayson Dawson 3/29/2021

SIZE

A

CODE

DWG NO

WEIGHT

REV

SHEET 1/1

SCALE 1:30